



Pressure transmitter CP 100

- Differential pressure transmitter type CP 100
- Measuring ranges from 0/+100 Pa to -1000/+2000 mbar (according to model, see "Configuration")
- Configurable intermediary and central zero ranges
- 0-10 V or 4-20 mA output, active sensor, power supply 24 Vac/Vdc (3-4 wires) or 4-20 mA output, passive loop, power supply 18 to 30 Vdc (2 wires)
- ABS IP 65 housing, with or without display
- Quick and easy mounting with the "1/4 turn" system with wall-mount plate

■ Features of the transmitter

Pressure

Working principle : a piezoresistive sensitive element creates a proportional voltage from the pressure applied on the sensor.

Measuring rangesee "Part number"

Unit of measurementPa, mmH₂O, mbar, inWG, mmHG (CP101 and CP102)
mbar, inWG, mmHG, KPa, PSI (CP 103 and CP 104)

Accuracy *±1,5% of reading ± 3 Pa (CP 101)
±1,5% of reading ± 3 mmH₂O (CP102)
±1,5% of reading ± 3 mbar (CP103 and CP104)

Response time1/e (63%) 0,3 sec.

Resolution1 Pa - 0,1 mmH₂O - 0,01 mbar - 0,01 inWG - 0,01 mmHG (CP101 and CP102)
1 mbar - 0,1 inWG - 1 mmHG - 0,1 KPa - 0,1 PSI (CP 103 and CP104)

Autozeromanual with push-button

Type of fluidair and neutral gases

Overpressure tolerated25000 Pa (CP 101), 7000 mmH₂O (CP 102),
1400 mbar (CP 103), 3000 mbar (CP 104).

■ Features of the housing

WITH or WITHOUT display

HousingABS

Fire-proof classificationHB as per UL94

Dimensionssee drawing beside

ProtectionIP 65

Display5-digit LCD. Dimensions 50 x 15 mm

Height of the digits10 mm

Connectionsbarbed fittings Ø 6,2 mm (CP 101 and CP 102)
compression fittings Ø 4 x 6 mm (CP 103 and CP 104)

Cable glandfor cable Ø 8 mm max.

Weight151 g (with display) - 116 g (without display)

■ Technical Specifications

Output / Power supplyactive sensor 0-10 V or 4-20 mA (power supply 24 Vac/Vdc ± 10%), 3-4 wires
passive loop 4-20 mA (power supply 18/30 Vdc), 2 wires
maximum load : 500 Ohms (4-20 mA)
minimum load : 1 K Ohms (0-10 V)

Consumption2 VA (0-10V) or max. 22 mA (4-20 mA)

Electro-magnetical compatibility ...EN 61326

Electrical connectionscrew terminal block for cables Ø 1.5 mm² max

Communication to PCKimo RS 232 cable

Working temperature0 to +50°C

Storage temperature-10 to +70°C

Environmentair and neutral gases

■ Part number

To order, just add the codes to complete the part number.

Measuring range

1	-500/+1000 Pa	For the intermediary and central zero ranges, see "Configuration".
2	-500/+1000 mmH ₂ O	
3	-250/+500 mbar	
4	-1000/+2000 mbar	

Transmitter / power supply / output

A	Active • 24 Vac/Vdc • 0-10 V or 4-20 mA
P	Passive • 18/30 Vdc • 4-20 mA

Display

O	With display
N	Without display

CP 10 - [] - [] []

Example : CP 103-AO

Model : pressure transmitter CP 100, measuring range -250/+500 mBar, active sensor, 0-10 V or 4-20 mA output, with display.

■ Dimensions of the housing (including the wall-mount plate)

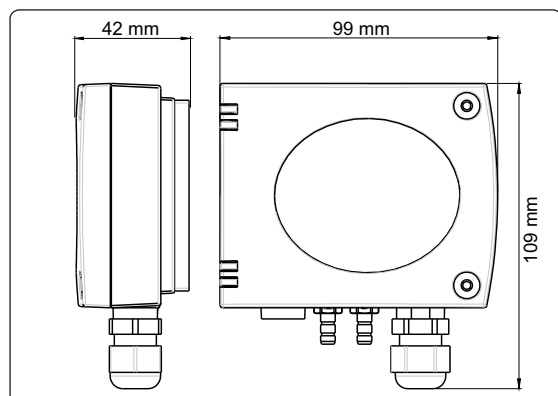

*All the accuracies indicated in this technical datasheet were stated in laboratory conditions, and can be guaranteed for measurements carried out in the same conditions, or carried out with calibration compensation.

Connection



For the models

CP 101 - AO and **CP 102 - AN** • output 0-10 V or 4-20 mA - **active**
103
104

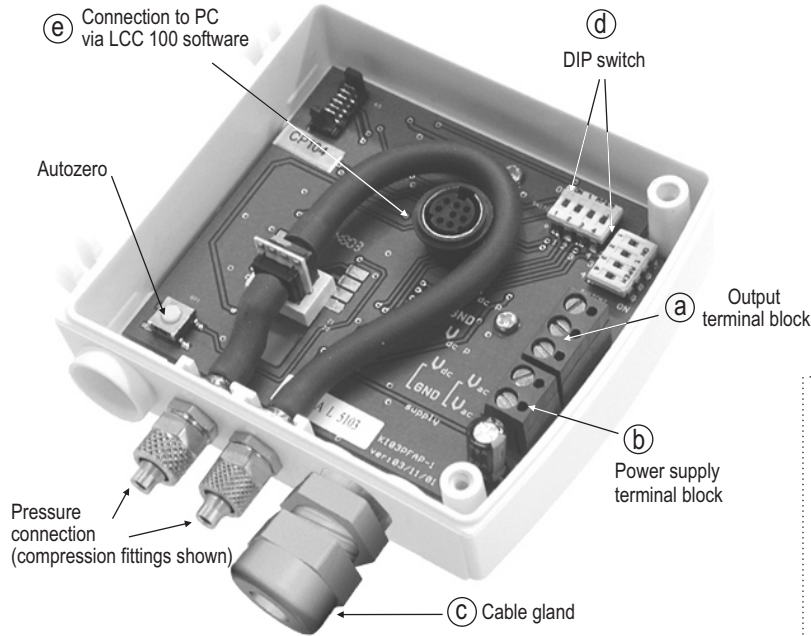

Output 0-10 V

- (a) GND ground
 Vdc P direct voltage (pressure)

OR

Output 4-20 mA

- (a) Idc P direct current (pressure)
 GND ground

Direct power supply

- (b) Vdc direct voltage
 GND ground

OR

Alternative power supply

- (b) Vac alternative voltage (phase)
 Vac alternative voltage (neutral)

For the models

CP 101 - PO and **CP 102 - PN** • Output 4-20 mA - **passive**
103
104

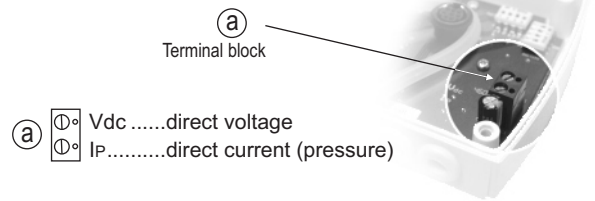

- (a) Vdc direct voltage
 IP direct current (pressure)

Electrical connections - as per norm NFC15-100

! This connection must be made by a qualified technician. To make the connection, the transmitter must not be energized.

For the models

CP 101 - AO and **CP 102 - AN** • output 0-10 V or 4-20 mA - **active**
103
104

4 wires

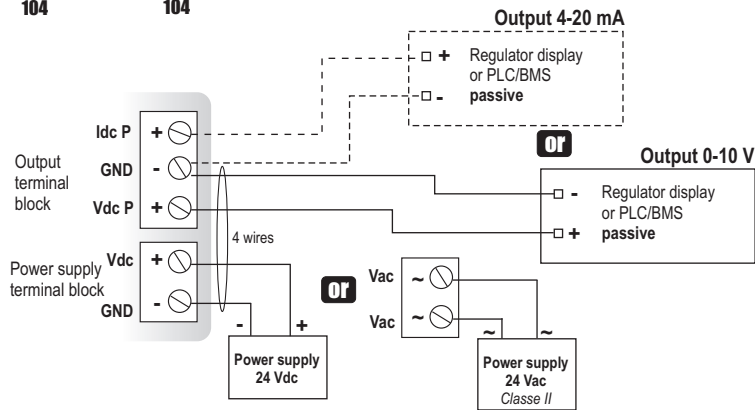

3 wires

! To make a 3-wire connection, **before powering up the transmitter**, please connect the output ground to the input ground. See drawing below.

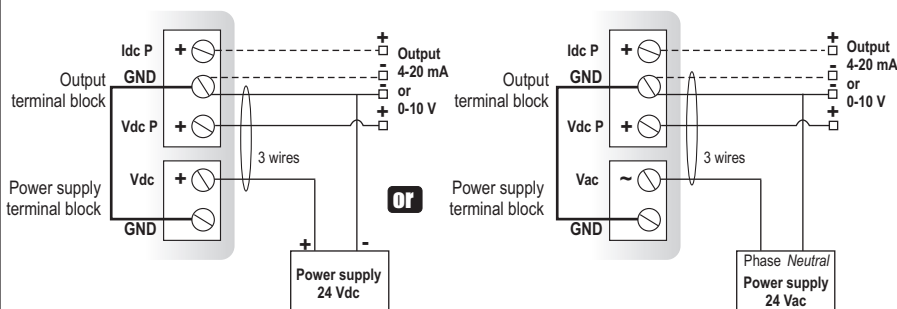

For the models

CP 101 - PO and **CP 102 - PN** • output 4-20 mA - **passive**
103
104

2 wires

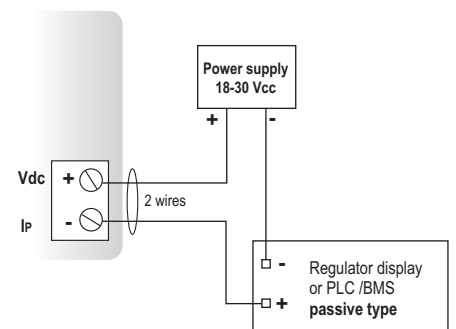

OR

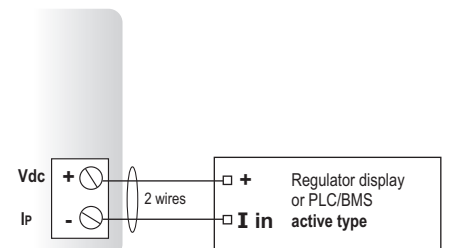

Autozero

To make an autozero, please disconnect the 2 pressure connections and briefly press on the push-button.

Configuration

It is possible to configure the measuring ranges, the units, the output of the instrument (according to the model) either by **switch** and/or via **software** (connections ③ and ④ on drawing "connection").

Configuration by the DIP switch

To configure the instrument, please unscrew the 2 screws from the housing, and then open it.



To configure the transmitter, **it must not be energized**. Then, you can make the settings required, with the DIP switches (as shown on the drawing beside). When the transmitter is configured, you can power it up.

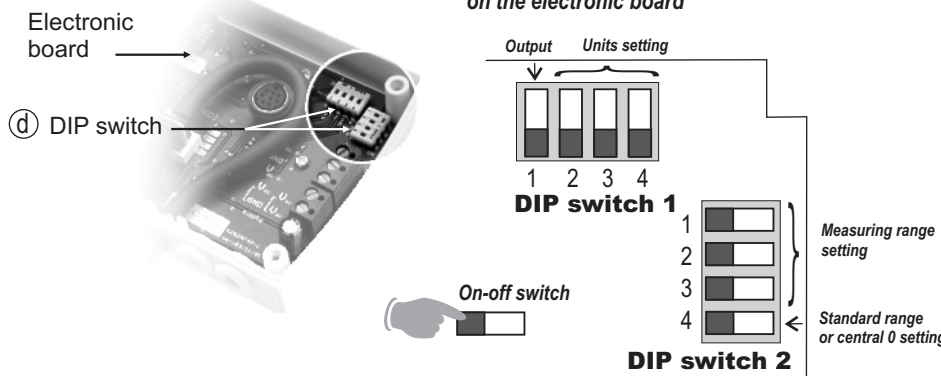

Caution!
Please follow carefully the combinations beside with the DIP switch. If the combination is wrongly done, the following message will appear on the display of the transmitter "CONFERROR". In that case, you will have to unplug the transmitter, place the DIP switches correctly, and then power the transmitter up.

Output setting DIP switch 1

To set the type of analogic output, please put the on-off switch of the output as shown beside. (For models CP 101 - AO and CP 101 - AN)

102	102
103	103
104	104

Configurations	4-20 mA	0-10 V
Combinations		
	1 2 3 4	1 2 3 4

Units setting DIP switch 1

To set the measuring unit, put the on-off switches 2, 3 and 4 of units as shown beside.

Configurations	Pa	mmH ₂ O	mbar	inWG	mmHG	KPa	PSI
Combinations							
	1 2 3 4	1 2 3 4	1 2 3 4	1 2 3 4	1 2 3 4	1 2 3 4	1 2 3 4
CP101 and CP 102	X	X	X	X	X		
CP103 and CP 104			X	X	X	X	X

Measuring range setting DIP switch 2

To set the measuring range, put the on-off switches 1, 2 and 3 of the measuring range as shown beside.

Example:
0 ----> +750 mmH₂O, the measuring range is 750 mmH₂O
-500 Pa ----> +500 Pa, the measuring range is 1000 Pa

To configure other intermediary ranges, and for an easier and more friendly configuration, please refer to "Configuration via software".

Combinations	1		2		3		4	
		1	2	3	4	1	2	3
CP 101	Pa	100	250	500	750	1000		
	mmH ₂ O	10,0	25,0	50,0	75,0	100,0		
	mbar	1,00	2,50	5,00	7,50	10,00		
	inWG	0,40	1,00	2,00	3,00	4,00		
	mmHG	0,80	2,00	4,00	6,00	8,00		
CP 102	mmH ₂ O	100,0	250,0	500,0	750,0	1000,0		
	Pa	1000	2500	5000	7500	10000		
	mbar	10,00	25,00	50,00	75,00	100,00		
	inWG	4,00	10,00	20,00	30,00	40,00		
	mmHG	8,00	20,00	40,00	60,00	80,00		
CP 103	mbar	100	200	300	400	500		
	inWG	40,0	80,0	120,0	160,0	200,0		
	Kpa	10,0	20,0	30,0	40,0	50,0		
	PSI	2,0	4,0	6,0	8,0	10,0		
	mmHG	80	160	240	320	400		
CP 104	mbar	500	750	1000	1500	2000		
	inWG	200,0	300,0	400,0	600,0	800,0		
	Kpa	50,0	75,0	100,0	150,0	200,0		
	PSI	10,0	15,0	20,0	30,0	40,0		
	mmHG	400	600	800	1200	1600		

Standard range / central zero setting DIP switch 2

To set the type of range, put the on-off switch 4 as shown beside:

Example : standard / 0 (0 / 100 Pa)
central zero (-50 Pa / 0 / +50 Pa)

Configurations	Full scale	central zero
Combinations		
	1	1
	2	2
	3	3
	4	4

■ Initialization of the transmitter

When the transmitter is powered up, it initializes and displays the digits $\boxed{0.0000}$, and then its configuration including :
 - the measuring range
 - the analog output.

1- The measuring range

The following message is displayed : \boxed{Lo} . This is the low value of the measuring range, and its digit value : **ex** : $\boxed{-500}$.
 The following message is displayed : \boxed{Hi} . This is the high value of the measuring range and its digit value : **ex** : $\boxed{500}$.
 The arrow displayed (at the bottom or on the right of the screen) is relative to the unit of measurement : **ex** : from -500 to +500 Pa.

2 - The analog output

If the analog output is in 4-20 mA, then the following message will appear $\boxed{4-20A}$.
 If the analog output is 0-10 V, then the following message will appear $\boxed{0-10V}$.

After the display of the configuration, the transmitter displays $\boxed{-----}$, which confirms that the initialization is finished and you can start the measurements.

■ Configuration via software (with optional LCC 100 software)



An easy and friendly configuration with the software !

You can configure your own intermediary ranges.



Caution !

For a pressure transmitter, the minimum configurable range is 10% of the full positive range.

Example : for a transmitter with a range of -500 / +1000 Pa, the minimum configurable range is 100 Pa.
 For example, you can configure your transmitter with a range of -20 to +80 Pa, from 0 to +600 Pa, or from -450 to +450 Pa...

• To access the configuration via software :

- Set the DIP switches as shown beside. **Nota** : the on-off switch 1 of the DIP switch 1 can be in any position (selection of the analogic output 0-10 V or 4-20 mA).
- Connect the cable to the transmitter plug (see "connections").

• Please refer to the user manual of the LCC 100 to make the configuration.

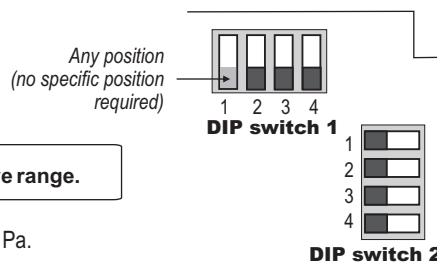

Caution !

The configuration of the parameters can be done **either with the DIP switch or via software** (you cannot combine both solutions)

■ Mounting

Installation : mount the ABS plate on the wall (this plate is supplied with the transmitter). Drilling : \varnothing 6 mm (with the screws and pins supplied with the transmitter). Insert the transmitter on the plate (see A on the drawing beside) and rotate its housing in clockwise direction until you hear a "click", which confirms that the transmitter is correctly installed.



Caution !

Once the transmitter is installed and powered up, please make an autozero to guarantee the correct working of the transmitter in any position.

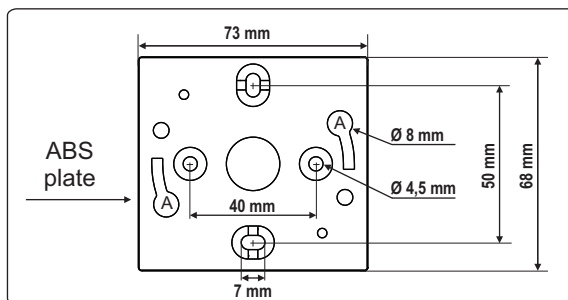

■ Maintenance

Please avoid any aggressive solvent.
 Please protect the transmitter and its probes from any cleaning product containing formol, that may be used for cleaning roots or ducts

■ Options

- Power supply class 2, input 230 Vac, output 24 Vac, ref.KIAL-100A
- Configuration software LCC 100 supplied with connection RS 232 cable



■ Accessories

- Connection tube
- Connection fittings
- Through-connections
- Straight connections
- Spherical coupling nut

